

PRIOCAB Typ90

Under-table safety cabinet according to DIN EN 14470-1



Fire resistant, double-leaf under table type 90 safety cabinet for proper storage of flammable liquids and solid materials in work areas. Type 90 safety cabinets, tested and certified in accordance with EN 14470-1, offer a fire resistance rating of 90 minutes, and are GS (geprüfte Sicherheit - tested safety) certified.

The cabinets offer an extraordinary level of stability and a long service life. The base material is high-density, and does not represent a fire load.

The high-quality interior and exterior surfaces are easy to clean. The doors of the safety cabinets close automatically in case of a fire.

Function

- GS Certificates
- Fire resistance 90 minutes
- Safety cabinet Typ90 according to EN 14470-1
- Suitable for the storage of inflammable fluids



- Door-closing mechanism, free-running



- Drain pan with perforated plate insert



- Shelve, 75 kg bearing load

Construction & Equipment

- Under-table safety cabinet with high-quality surface inside and outside
- Single-layer doors and walls made of homogeneous solid material
- Double-leaf version (width 1100 mm)
- In case of fire, self-closing ventilation openings at the rear, connections DN 100 mm
- Free-wheeling doors with thermally induced closure in case of fire
- Different equipment variants
- Fittings adjustable in 32 mm hole spacing
- Floor pan with perforated plate insert for use as a fourth storage level
- Grounded tank bottom, tilt resistant with a central hole for systematic removal of leakage

Material & Surface

- Standard surface CP laminate
- Building material with surface coating, classified A2 – s1, d0: non-combustible
- Surface light grey, similar to RAL 7035

Under-table safety cabinet 2-leaf, EN92U

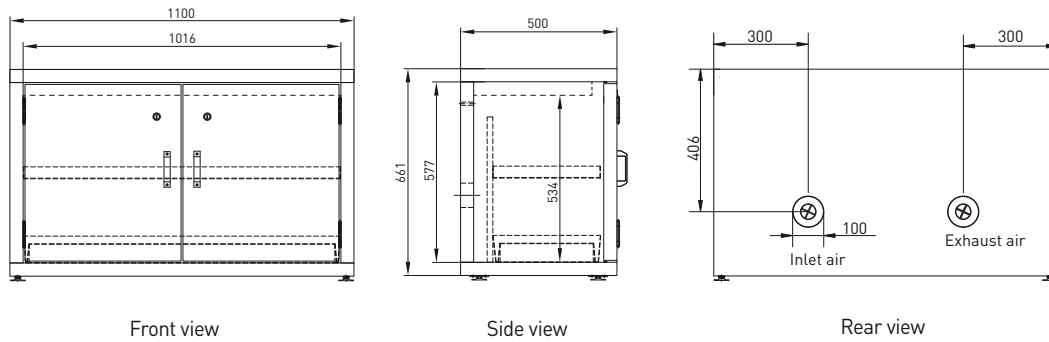

Application examples

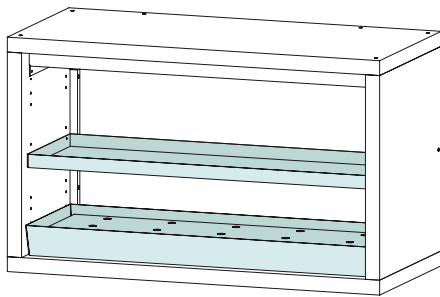



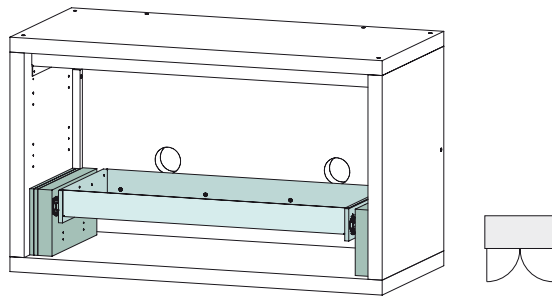

EN92U:067-110

1 tank bottom, 1 floor pan with perforated plate insert



EN92U:067-110-1A

1 Fully-extendable shelf

Art.	Code ¹	 H x W x D mm	 H x W x D mm	 kg	 l	Features	Material
Under-table safety cabinet, 2-leaf Typ90 with free-wheeling doors							
EN92U:067-110	x	534 x 1016 x 355	661 x 1100 x 500	223	24	1 tank bottom, 1 floor pan, 1 perforated plate insert	Sheet steel, powder coated, RAL 7035
Under-table safety cabinet, 2-leaf Typ90 with free-wheeling doors and pull-out shelf							
EN92U:067-110-1A	x	534 x 1016 x 355	661 x 1100 x 500	223	1 x 19	1 fully-extendable shelf, load capacity 75 kg	Sheet steel, powder coated, RAL 7035

¹Colour code x: 1 = Doors and plinth panel in yellow, similar to RAL 1023
without = Standard product, light grey, similar to RAL 7035

Order example:

EN92U:067-110-1A-1 → Under-table safety cabinet, 2-leaf Typ90 with free-wheeling doors and pull-out shelf, doors and plinth panel painted on the outside in RAL 1023

Options and accessories

- Doors and entire body in alternative RAL colours / surfaces, on request
- Tank bottoms, max. load 75 kg
- Fully extendable shelf, max. load 75 kg
- Load increase to 150 kg
- Floor pan incl. perforated plate insert
- Perforated plate insert
- Fine (pre)filter for EBEL:VENT-EN-U (replacement)
- Replacement active charcoal filter for EBEL:VENT-EN-U
- Single cable and pipe-penetration
- Recirculated air attachment, ready to plug in



EBEL:VENT-EN-U
Recirculated air attachment
Technical specifications see page: 16

Art.	Accessories	 H x W x D mm
EKRD90-014-014	Single cable and pipe-penetration for EN cabinets, Type 90	
Supplementary equipment for Under-table safety cabinet Typ90, double-leaf		
EN92-TSF	Door closer with locking device and thermally induced closure	
EN92U-WBO	Tank bottom, configuration in steel sheet RAL 7035, powder-coated	38 x 1013 x 349
EN92U-BOW	Floor pan incl. perforated plate insert, configuration in steel sheet RAL 7035, powder-coated	91 x 1013 x 349
EN92U-LBE	Perforated plate insert, configuration in steel sheet RAL 7035, powder-coated	60 x 988 x 319
EN92U-AZ	Fully-extendable shelf, steel sheet, powder-coated, RAL 7035 (load capacity 75 kg, 19 litre collection capacity)	
Artificial ventilation		
EBEL:VENT-EN-U	Recirculated air attachment, ready to plug in incl. adapter set and connection hose	
HF.SF.9405	Fine (pre)filter for EBEL:VENT-EN-U (replacement)	
HF.AK.9404	Replacement active charcoal filter for EBEL:VENT-EN-U	



 Products for safe storage of lithium-ion batteries